

Marine Diesel Engine

MD196TI

- Compact Design
- Excellent Performance
- Low Fuel Consumption
- Easy Maintenance

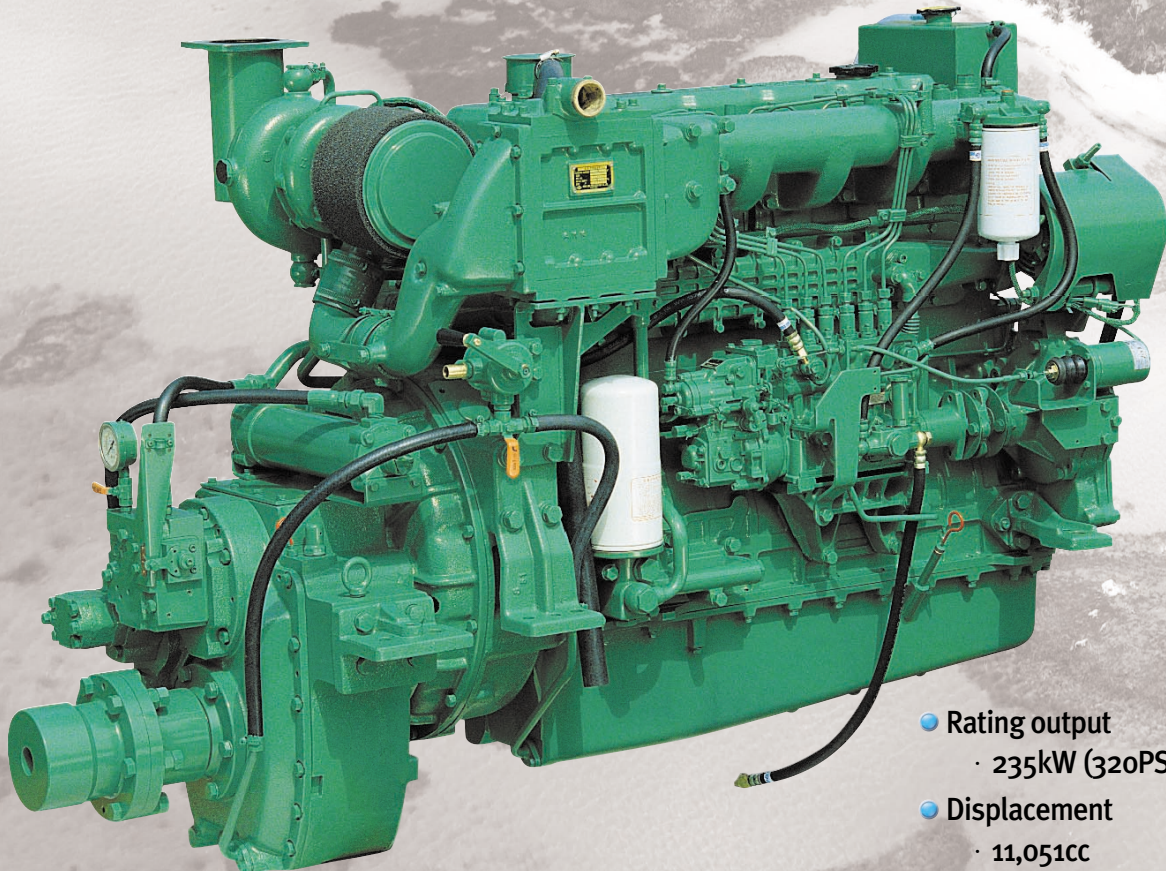

- Rating output
· 235kW (320PS)
- Displacement
· 11,051cc
- Dimension (L × W × H)
· 1,235 × 855 × 1,073mm
· Without Reduction Gear

Main Specification

Model	Units	MD196TI
Engine type		4cycle, In line, direct-injection, watercooled with wet turbo charger & inter-cooler
Rating output	PS(kW) / rpm	320(235) / 2,000
Displacement	cc	11,051
Cylinder number - bore × stroke	mm	6 - 123 × 155
Low idling rpm	rpm	750 ± 50
No load max. rpm	rpm	below 2,200
Compression ratio		16.5 : 1
Firing order		1 - 5 - 3 - 6 - 2 - 4
Governor type of injection pump		Mechanical variable speed (R.Q.V)
Fuel consumption(only Ref.)	g / PS.h	158
	Lit / h	61
Starting system		Electric Starting by starter motor
Starter motor capacity	V - kW	24 - 6.0
Alternator capacity	V - A	24 - 50
Battery	V - Ah	24 - 150
Cooling system		Indirect sea water cooling with heat exchanger
Cooling water capacity	Max. / Min.	lit 24 / 19
Fresh water pump type		Centrifugal type, driven by gear
Sea water pump type		Rubber impeller type driven by gear
Lubricating oil(Engine)	Pan capacity	lit Max : 25, Min : 19 (Engine total : 27)
Direction of revolution	Crankshaft	Counter clockwise viewed from stern side
Engine Size(L×W×H)	Without M/G	mm 1,235 × 855 × 1,073
Engine dry weight	Without M/G	kg 1,009

※ H : Heavy Duty, M : Medium Duty, L : Light Duty

Engine Dimension

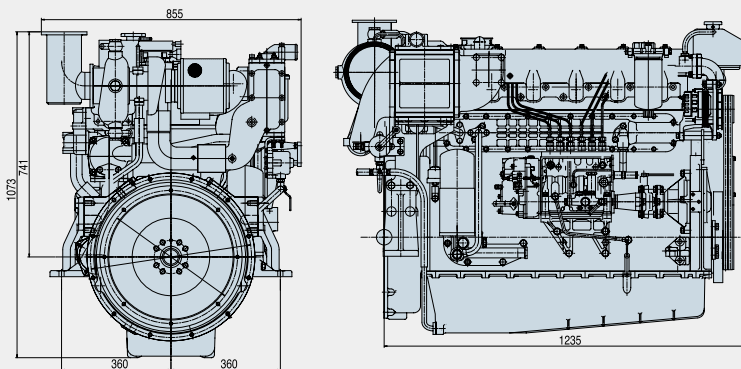

Performance Curve

· Heavy duty : 235kW(320PS)@2,000rpm

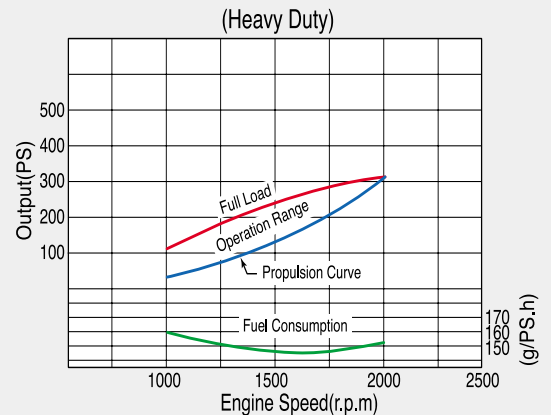

Marine rating to ISO 3046

(1) Heavy Duty

Operation hours are unlimited per year, at average load is up to 90 %, at full load is up to 80 %
 Typical gearbox ratio: 2.5 ~ 6
 (Fishing trawler, Tug boat, Pushing vessel, Cargo boat, Freighter, Ferry)

(2) Medium Duty

Operation hours are up to 3,000 per year, at average load is up to 70 %
 At full load is (up to 30 % / 4hrs per 12 hour operation period)
 Typical gearbox ratio: 2 ~ 3.5
 (Fishing boat, Pilot boat, Escort boat, Passenger boat, Ferry, Cruising vessel)

(3) Light Duty

Operation hours are up to 1,000 per year, at average load is up to 50 %
 At full load is (up to 20 % / 2hrs per 12 hour operation period)
 Typical gearbox ratio: 1 ~ 2.5
 (Light weight fishing boat, Yacht, Coastguard boat, Fast boat, Fire pump, Navy)

(Dec.2006)



**Doosan Infracore
Engines & Materials**

Seoul Office : Overseas Marketing & Sales
 Engines & Materials BG
 Doosan Infracore Co., Ltd.
 23rd Floor, Doosan Tower, 18-12, Euljiro 6-ga,
 Jung-gu, Seoul, Korea.
 Tel : +82-2-3398-8530~8546
 Fax : +82-2-3398-8509
Web site : <http://engine.doosaninfracore.co.kr>

AUTHORIZED DEALER

* Specifications are subject to change without prior notice.