

Marine Diesel Engine

L136TI

- Compact Design
- Excellent Performance
- Low Fuel Consumption
- Easy Maintenance

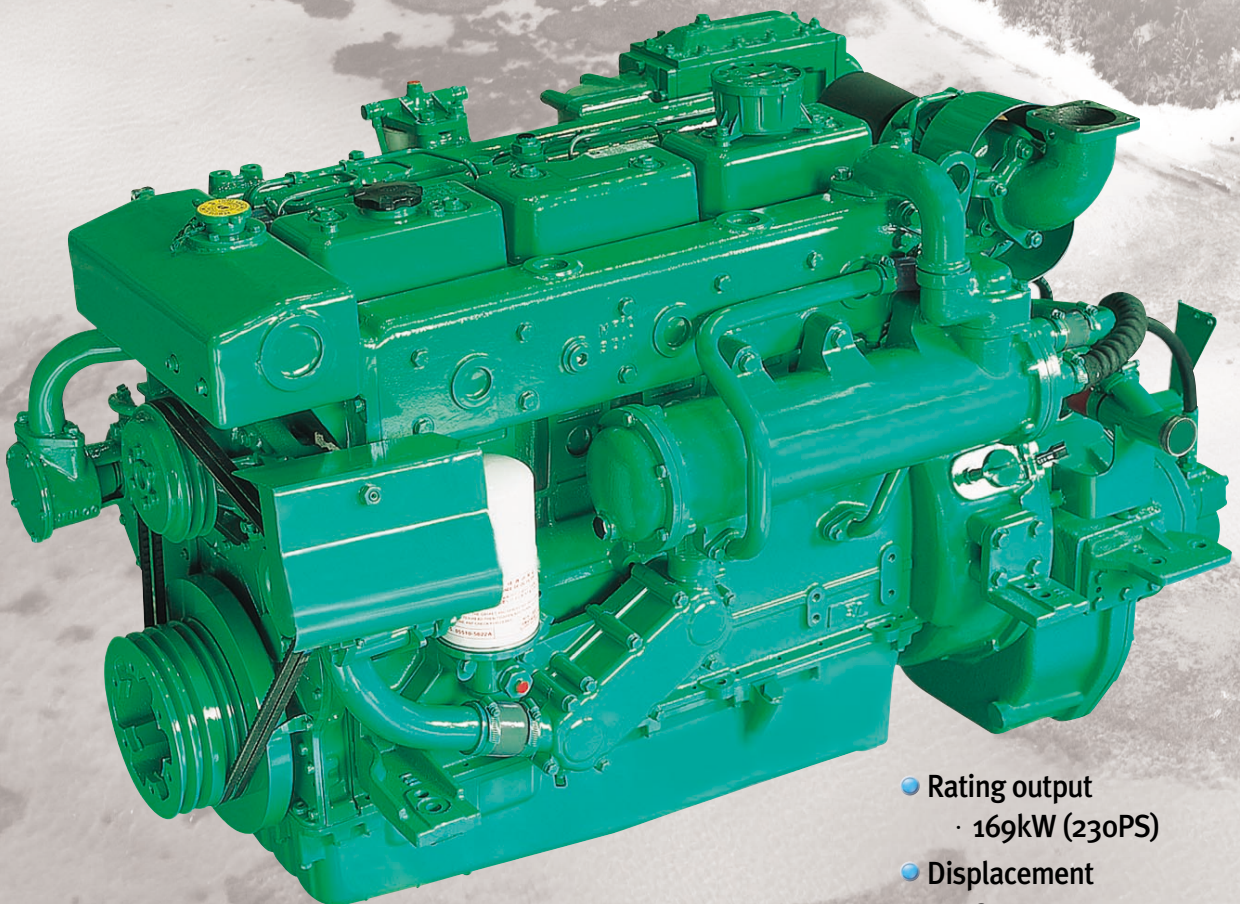

- Rating output
 - 169kW (230PS)
- Displacement
 - 8,071cc
- Dimension (L × W × H)
 - 1,188 × 825 × 926mm
 - Without Reduction Gear

Main Specification

Model	Units	L136TI
Engine type		4 cycle, In line, direct-injection, watercooled with turbo-inter cooler
Rating output	PS(kW)/rpm	230(169) / 2,200
Displacement	cc	8,071
Cylinder number - bore × stroke	mm	6 - 111 × 139
Low idling rpm	rpm	725 ± 25
No load max. rpm	rpm	below 2,400
Compression ratio		16.7 : 1
Firing order		1 - 5 - 3 - 6 - 2 - 4
Governor type of injection pump		Mechanical all speed (R.S.V)
Fuel consumption (only Ref.)	g / ps.h Lit/h	162 45
Starting system		Electric Starting by starter motor
Starter motor capacity	V - kW	24 - 4.5
Alternator capacity	V - A	24 - 50
Battery	V - Ah	24 - 100
Cooling system		Indirect sea water cooling with heat exchanger
Cooling water capacity	Max. / Min.	lit 27 / 25
Fresh water pump type		Centrifugal type, driven by V-belt
Sea water pump type		Rubber impeller type, driven by gear
Lubricating oil(Engine)	Pan capacity	lit Max : 23, Min : 17 (Engine total : 25)
Direction of revolution	Crankshaft	Counter clockwise viewed from stern side
Engine Size(L×W×H)	Without M/G	mm 1,188 × 825 × 926
Engine dry weight	Without M/G	kg 773

※ H : Heavy Duty, M : Medium Duty, L : Light Duty

Engine Dimension

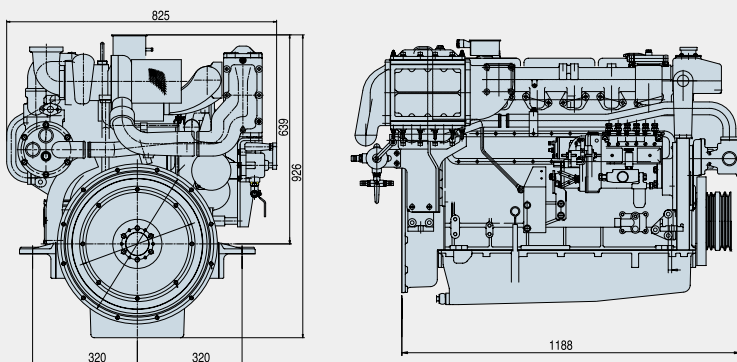

Performance Curve

· Heavy duty : 169kW(230PS)@2,200rpm

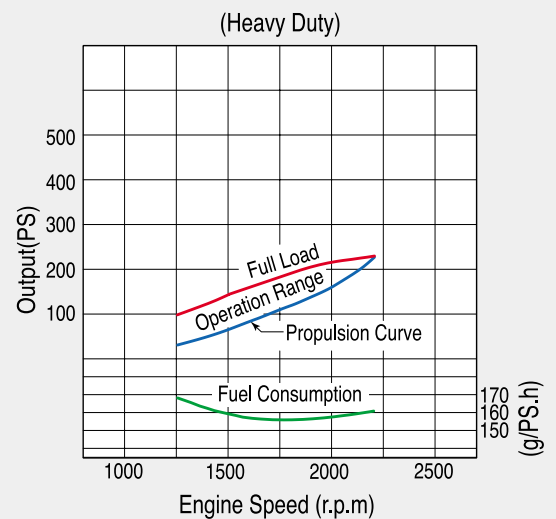

Marine rating to ISO 3046

(1) Heavy Duty

Operation hours are unlimited per year, at average load is up to 90 %, at full load is up to 80 %
Typical gearbox ratio: 2.5 ~ 6
(Fishing trawler, Tug boat, Pushing vessel, Cargo boat, Freighter, Ferry)

(2) Medium Duty

Operation hours are up to 3,000 per year, at average load is up to 70 %
At full load is (up to 30 % / 4hrs per 12 hour operation period)
Typical gearbox ratio: 2 ~ 3.5
(Fishing boat, Pilot boat, Escort boat, Passenger boat, Ferry, Cruising vessel)

(3) Light Duty

Operation hours are up to 1,000 per year, at average load is up to 50 %
At full load is (up to 20 % / 2hrs per 12 hour operation period)
Typical gearbox ratio: 1 ~ 2.5
(Light weight fishing boat, Yacht, Coastguard boat, Fast boat, Fire pump, Navy)

Dec./2006



**Doosan Infracore
Engines & Materials**

Seoul Office : Overseas Marketing & Sales
Engines & Materials BG
Doosan Infracore Co., Ltd.
23rd Floor, Doosan Tower, 18-12, Euljiro 6-ga,
Jung-gu, Seoul, Korea.
Tel : +82-2-3398-8530~8546
Fax : +82-2-3398-8509
Web site : <http://engine.doosaninfracore.co.kr>

AUTHORIZED DEALER

* Specifications are subject to change without prior notice.